

## Room Temperature Sensors

## QAA24...27

with and without setpoint adjuster

### Use

In heating, ventilating and air conditioning plants, especially where a high level of comfort is required.

Major field of application:  
Acquisition and adjustment of room temperature.

### Type summary

Type reference	Description
<b>QAA24</b>	Room temperature sensor
<b>QAA25</b>	Room temperature sensor with setpoint adjuster (setting range 5...35 °C)
<b>QAA26</b>	Room temperature sensor with setpoint adjuster (setting range 5...30 °C)
<b>QAA27</b>	Room temperature sensor with setpoint adjuster (setting range $\pm 3$ K)

### Ordering

When ordering, please give name and type reference, for example:  
Room temperature sensor **QAA24**

## Function

---

The sensor acquires the air temperature via its sensing element whose resistance changes as a function of the temperature.

The signal is delivered to a suitable controller for further handling.

### Sensing element

LG-Ni 1000

Characteristic:

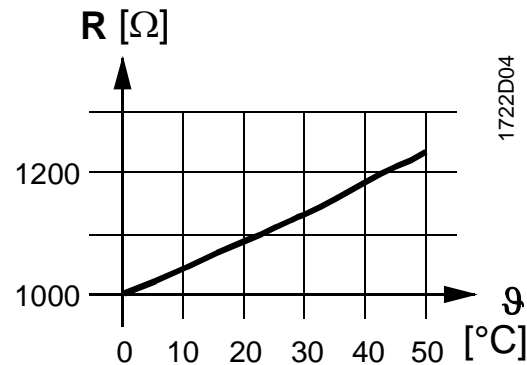

Accuracy:

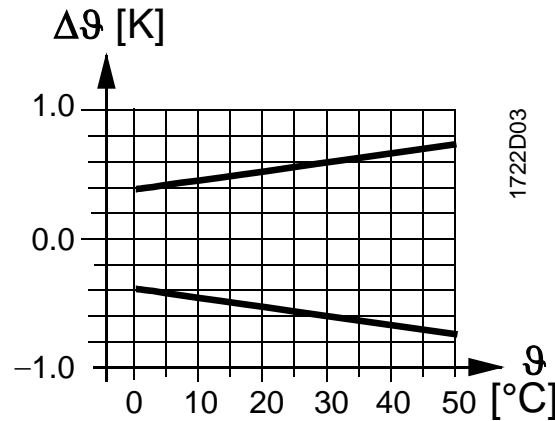

### Legend

R Resistance value in Ohm  
 $\vartheta$  Temperature in degrees Celsius  
 $\Delta\vartheta$  Temperature differential in Kelvin

## Mechanical design

---

The units have been designed for wall mounting. They are suitable for use with most commercially available recessed conduit boxes. The cables can be introduced from the rear (concealed wiring) or from below or above (surface-run wires) through knock-out openings.

The units consist of two major sections: Casing and baseplate. Both snap together but can be detached again. The casing accommodates the temperature sensing element and, depending on the type of unit, various setting and operating elements. The baseplate carries the connecting terminals.

## Setting and operating elements

(only with QAA25, QAA26 and QAA27)

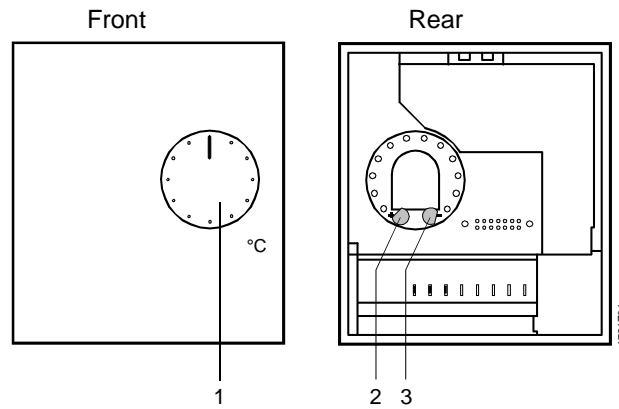

### Legend

- 1 Setting knob for infinite setpoint adjustment
- 2 Pin for mechanical maximum limitation of setpoint setting range
- 3 Pin for mechanical minimum limitation of setpoint setting range

## Disposal

The major plastic components bear the material references in compliance with ISO/DIS 11 469 to facilitate environment-friendly disposal.

## Engineering notes

---

For the permissible lengths of lines and measured value errors, refer to «Basic System Data» of the respective control system.

Following applies to the following systems/devices:

- UNIGYR®/VISONIK®

When using the **QAA26**, both the temperature sensor and the setpoint setting unit must be connected to a measured value input (B...) of the measured value module (PTM1.2R1K).

## Fitting and installation notes

---

### Location

On an inner wall of the space to be heated or air conditioned. Not in recesses, shelves, not behind curtains, not opposite or near heat sources.

The unit must not be exposed to direct solar radiation.

The end of the conduit at the sensor must be sealed to prevent false measurements due to draughts through the conduit.

The permissible ambient conditions should be observed.

### Installation instructions

Installation instructions are printed on the packing.

## Disposal

---



The devices are considered electronics devices for disposal in term of European Directive 2012/19/EU and may not be disposed of as domestic waste.

- Dispose of the device via the channels provided for this purpose.
- Comply with all local and currently applicable laws and regulations.

## Technical data

---

<b>Sensor</b>	Range of use	0...50 °C		
	Sensing element	LG-Ni 1000		
	Time constant	7 min (depending on air movement and thermal coupling to the wall)		
	Max. permissible line lengths and measured value errors	refer to «Engineering notes»		
<b>Setpoint setting knob</b>		<b>QAA25</b>	<b>QAA26</b>	<b>QAA27</b>
	Setpoint setting range	5...35 °C	5...30 °C	±3 K
	Resistance range	95...685 Ω	1000...1195 Ω	1000...1175 Ω
	Resistance value at setpoint			0 K ≧ 1091 Ω
	10 °C	193,9 Ω	1039 Ω	
	20 °C	390,0 Ω	1118 Ω	
	25 °C	488,3 Ω	1157 Ω	
30 °C	586,7 Ω	1195 Ω		
<b>General data</b>				
Connection terminals	Connection terminals for cross-sectional areas of	2 x 1.5 mm <sup>2</sup> or 1 x 2.5 mm <sup>2</sup>		
Degree of protection	Protection degree of housing Protection class	IP30 according to EN 60529 III according to EN 60730		
Environmental conditions	Operation to	EN 60721-3-3		
	Climatic conditions	class 3K5		
	Temperature	0...50 °C		
	Humidity	0...95 % r. h. (noncondensing)		
	Mechanical conditions	class 3M2		
	Transport to	EN 60721-3-2		
Climatic conditions	class 2K3			
Temperature	-25...+65 °C			
Humidity	<95 % r. h.			
Mechanical conditions	class 2M2			
Directives and Standards	Product standard	EN 60730-1 Automatic electrical controls for household and similar use		
	EU Conformity (CE)	CM1T1721xx		
Materials and colors	Housing front	ASA+PC, NCS S 0502-G (white)		
	Bottom section of housing	ASA+PC, NCS 2801-Y43R (grey)		
	Base	PC, NCS 2801-Y43R (grey)		
	Sensor (entirely)	silicon-free		
Weight	with packaging	approx. 0,1 kg		

\*) The documents can be downloaded from <http://siemens.com/bt/download>.

## Internal diagram

QAA24

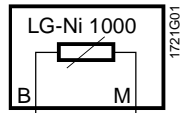

QAA25, QAA26

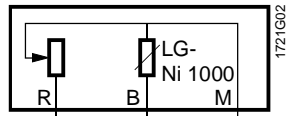

QAA27

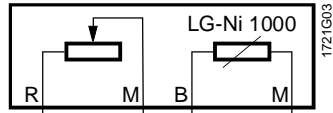

Legend

B1 Room temperature measuring signal  
M Measuring neutral  
R Setpoint signal

## Dimensions

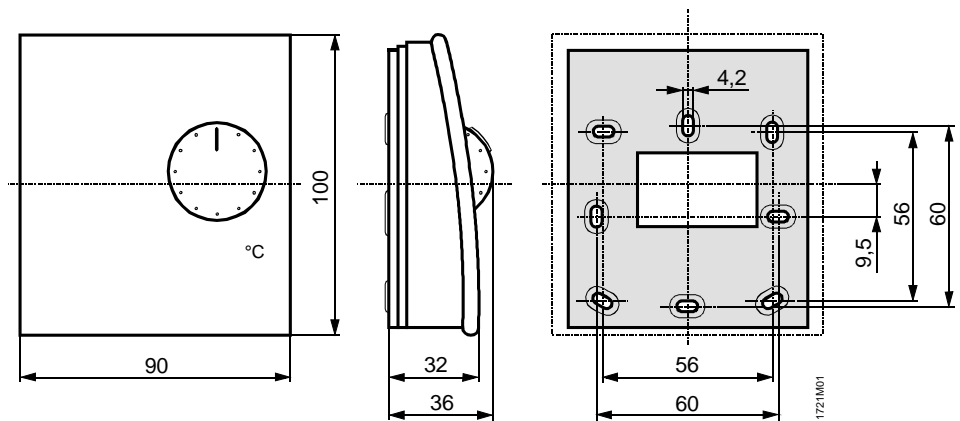

Dimensions in mm