

**LEASAM BM2GZ SERIES CONTROLLERS (24V or 240VAC Switching)
COMMISSIONING/ INSTALLATION INSTRUCTIONS Ver 2.3.4**

Caution : Disconnect power supply and insure that all wiring complies with applicable codes.

The above Leasam models are a two part Temperature Control system, comprising a Wall Control Pad with Integral sensor and a Relay Module. Optional extras - Wall Control Pad and sensors can also be added to system (see wiring diagrams). Take care with the location of Wall Control Pad when using integral sensor and optional remote sensors. Fix to an internal flat wall surface approximately 1500mm above floor level and at a location to sense average room temperature. Avoid locating in direct sunlight or sources of hot or cold drafts directly on or near the Wall Control sensing element.

Fix mounting plate to plasterboard

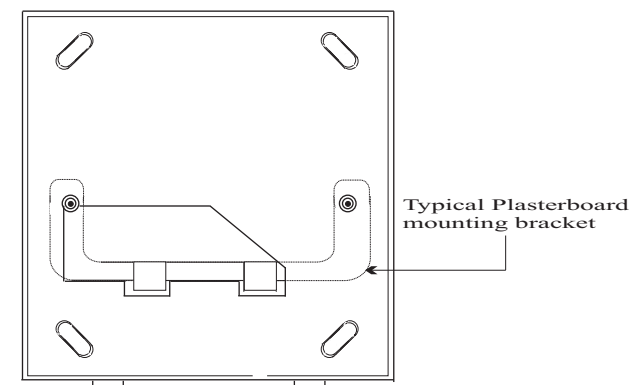

Wall Control wiring connections

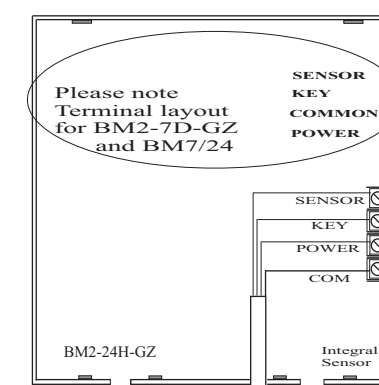

Fix Wall Control Pad to mounting plate

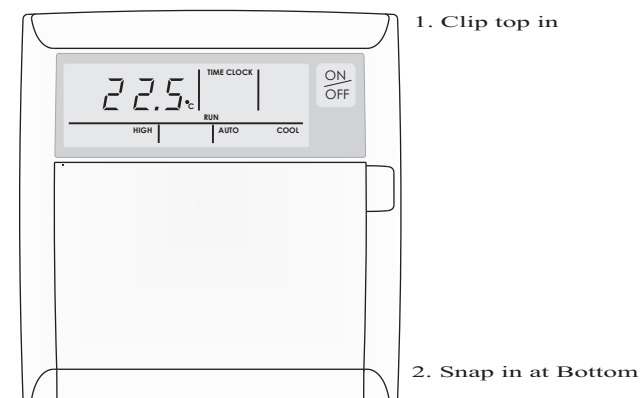

BM7/BM24

Remove Wall Control Pad from mounting plate

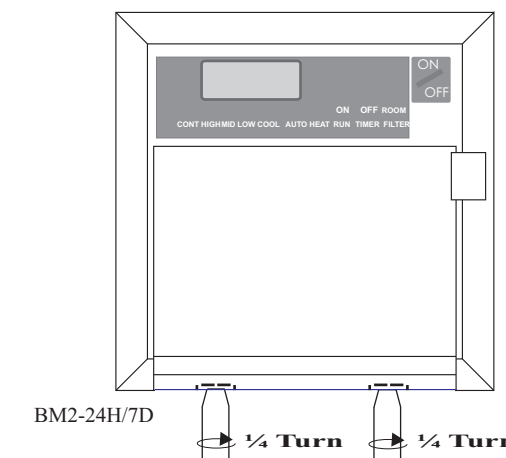

BM2-24H/7D

Insert flat screw driver into slots and turn

**For LEASAM Technical Enquiries - Free Call 1300 135 735 normal office hours.
For Wall Control Operating Button. See Customer Operating Instructions.**

INDEX	PAGE
Commissioning and Service keys.	2
Factory Settings and adjustments, Menus	
Menu 1	2
Select Air Conditioning Operating Options.	
Menu 2	3
Temperature switching differential adjustments.	
Menu 3 Overview	3
Section 1	4
Add or Remove Zones. on 4Z Models.	
Assigning optional Wall Control Pad or sensors to Zones 2, 3 or 4	
Section 2	
Select operating fan speeds and fan operation.	4
Section 3.	
Fan run-on time, temperature operating mode, Sensor 1 and 2 calibration, Compressor delay	
Dirty Filter indicator, change 4 way valve operate in cooling, Sensor 3 functions.	
Power wiring diagrams.	5
Wall Control wiring diagrams.	6
Typical wiring diagram	7

COMMISSIONING AND SERVICE KEYS

Reset Control to Factory Default Settings. Press ON/OFF button to turn off Wall Control

Press and Hold FAN CONTROL button in.
Press and release SET TEMP Down arrow.
Press ON/OFF button and release with FAN CONTROL button

Wall Control lights will flash and system will reboot. Non factory settings will have to be re-programmed.

Display Room Temperature for 30 minutes.

Press and Hold FAN CONTROL button in.
Press COOL button and release both buttons together.

ROOM light will flash and room temperature will be displayed. Press any button to exit menu.

Display Room Temperature for 3 seconds.

Quick press on TIMER Up arrow. ROOM light will flash and room temperature will be displayed.

Cancel Operating Timers. Compressor anti-cycle, Fan run-on and Reversing Valve Hold In time.

Press and hold FAN CONTROL button in, press HEAT button, then release both buttons together.

To Allow All Zones to be Turned Off.

Press and hold ZONE 1 button in, press ON/OFF button, then release both buttons together.

See 1on displayed, this means 1 Zone must remain ON. Press SET TEMP Up arrow
See 1oF displayed, this means all Zones can be turned OFF. Press FAN CONTROL button to EXIT.

Temperature Set Point Range Limits. Press ON/OFF button to turn off Wall Control.

Set Upper limit. Factory default setting 28oC. Maximum setting 30oC

Press and release in quick succession the TIMER Up arrow then SET TEMP Up arrow.

While the lights are flashing and Upper set point displayed, quickly press and hold SET TEMP Up or Down arrow to select new upper set point range. Automatically exits menu after 5 seconds.

Set Lower limit. Factory default setting 16oC. Minimum setting 10oC

Press and release in quick succession the TIMER Down arrow then SET TEMP Down arrow.

While the lights are flashing and Lower set point displayed, quickly press and hold SET TEMP Down or Up arrow to select new lower set point range. Automatically exits menu after 5 seconds.

MENU 1. Air Conditioner Operating Modes Press ON/OFF button to turn off Wall Control.

Press and hold FAN CONTROL button in, then press TIMER button and release BOTH buttons together.

Screen will display factory setting: HP (single stage heat pump).
Pressing the SET TEMP Up or Down arrow will allow other "Air Conditioning Operating Options" to be selected.
Press FAN CONTROL button to accept that selection and exit Menu.
Alternatively press TIMER button to accept that selection and move to Menu 2.

Air Conditioning Operating options.

- a) HP : (Factory setting) Single Stage Heat Pump, for auxiliary Boost Heat Output, enable Fan Runon.
- b) 2HP : Two Stage Heat Pump.
- c) CE : Two Stage Heat and One Stage Cool.
- d) 2CE : Two Stage Cool and One Stage Heat.
- e) 3H : Three Stage Heat.
- f) 3C : Three Stage Cool.

See part Relay Module wiring connections below. See also typical wiring diagram page 7.

FACTORY SETTING

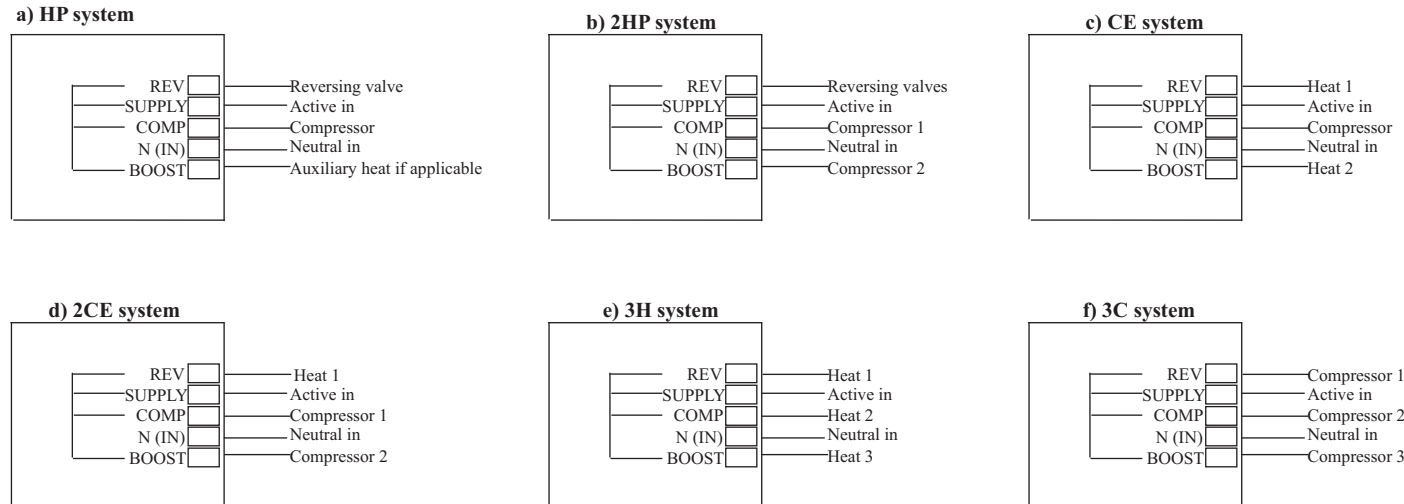

Typical Wiring Diagram including external stop/start (Home Automation) and preheat start sensor.
For other control systems see Wiring Diagrams on Pages 5 & 6 .

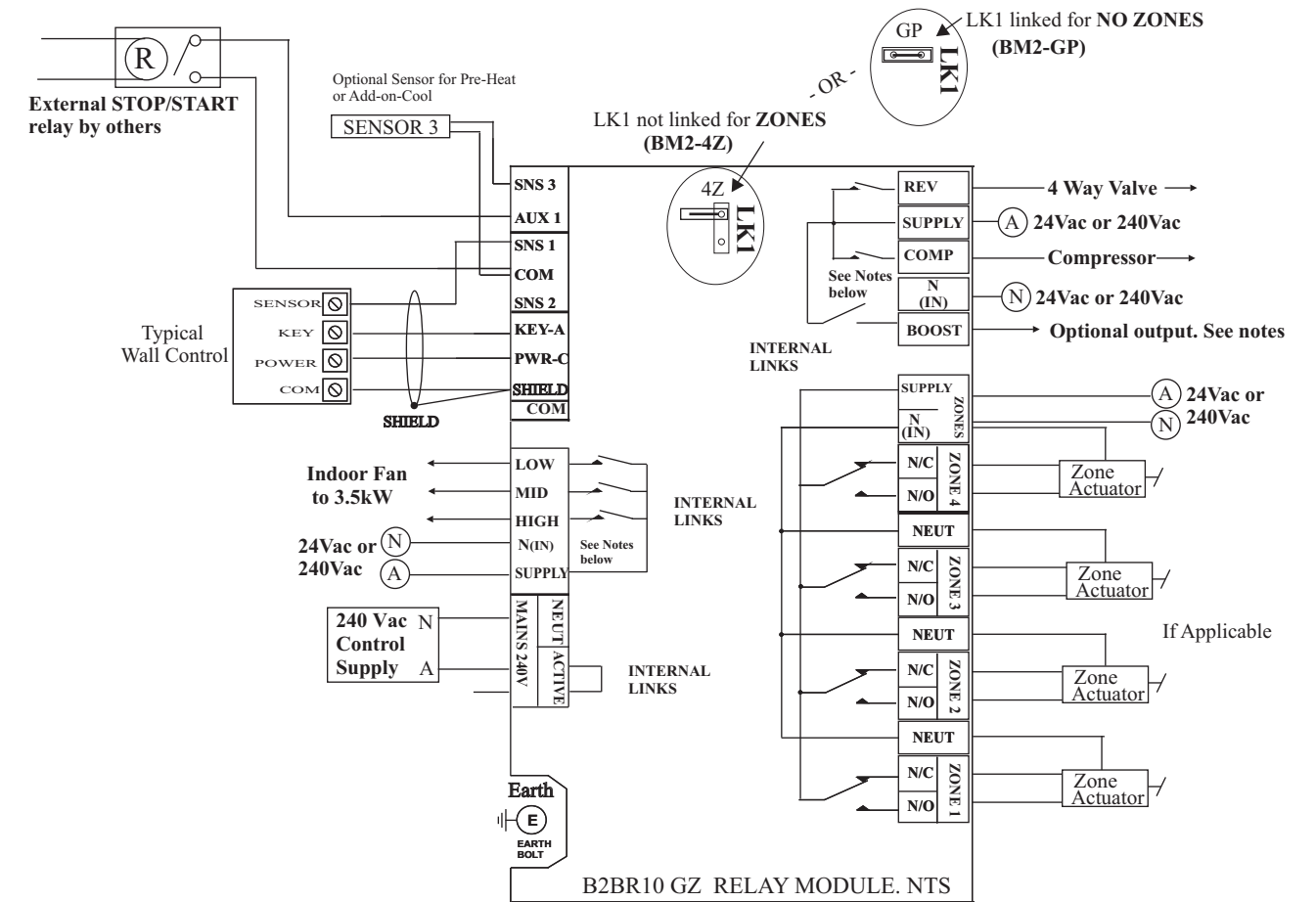

NOTES

FIT LK1 across the 2 pins if NO ZONES are used.

N(IN) TERMINALS. Important that neutral is connected into this terminal.
If using 240 V control system (typical A/C units), loop supply neutral into the N(IN) terminals.
If using 24 V control system (some imported models) connect 24 V control neutral into the N(IN) terminals. See wiring diagram page 5.

ZONE ACTUATORS.
240 Vac or 24 Vac output for 2 or 3 wire zone actuators.

BOOST TERMINAL.
See Air Conditioning Options on Page 2 for Heat Pump + Boost Heat Option.

OPTIONAL SENSOR 3.
Used as an indoor coil preheat sensor if secured to evaporative coil or supplementary heating call if measuring ambient temperature.

HOME AUTOMATION SET UP (remote ON / OFF)

Connect Relay (isolated contacts) between terminals "AUX 1" and "COM", see above.

To TURN A/C SYSTEM ON - CLOSE RELAY contacts
Ensure relay is open before closing relay contacts (5 second delay before system starts).

To TURN A/C SYSTEM OFF - OPEN RELAY contacts
Ensure relay is closed before opening relay contacts

Note: Wall Control ON / OFF button still operates.

Wall Control to Relay Module wiring options.

A. Standard connections

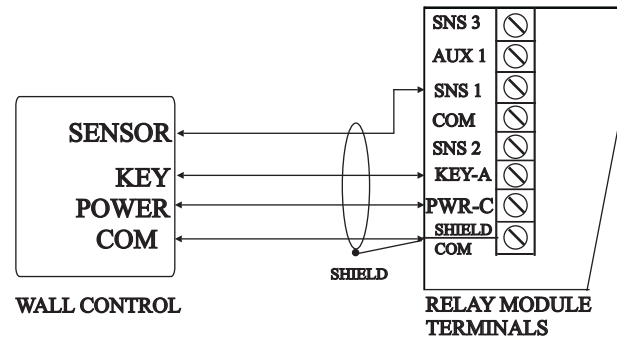

B. Remote Sensor. Wall Control sensor not used

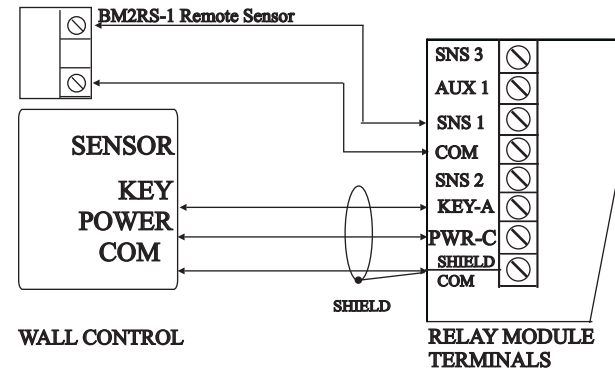

C. Two sensor control.

Zone Tracking for BM2 4Z models.
Temperature averaging for BM2 GP models.

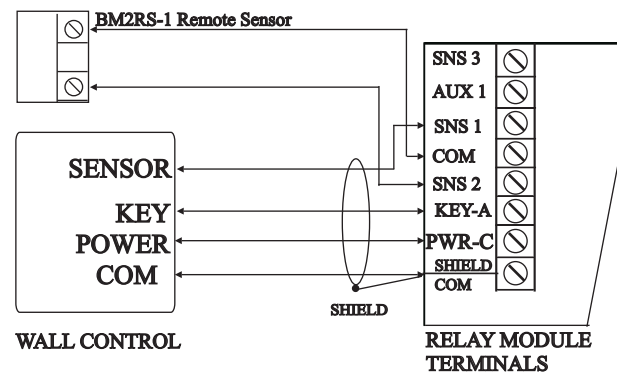

D. Two sensor control. Wall Control sensor not used.

Zone Tracking for BM2 4Z models.
Temperature averaging for BM2 GP models.

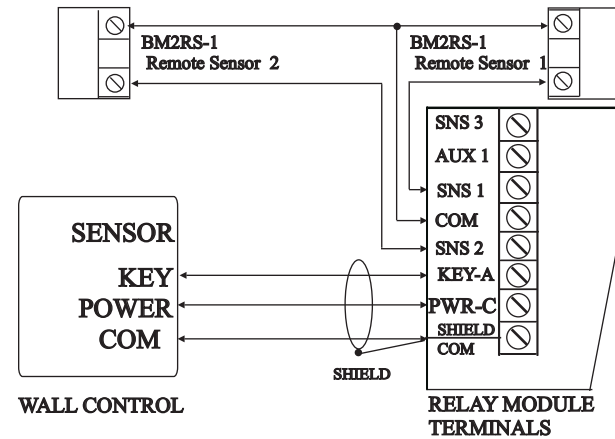

E. Two Wall Control Pads.

Only one 7-Day Wall Control should be used per system, the second wall control should be 24Hour model e.g. BM7 and BM24.
Zone Tracking for BM2 4Z models.
Temperature averaging for BM2 GP models.

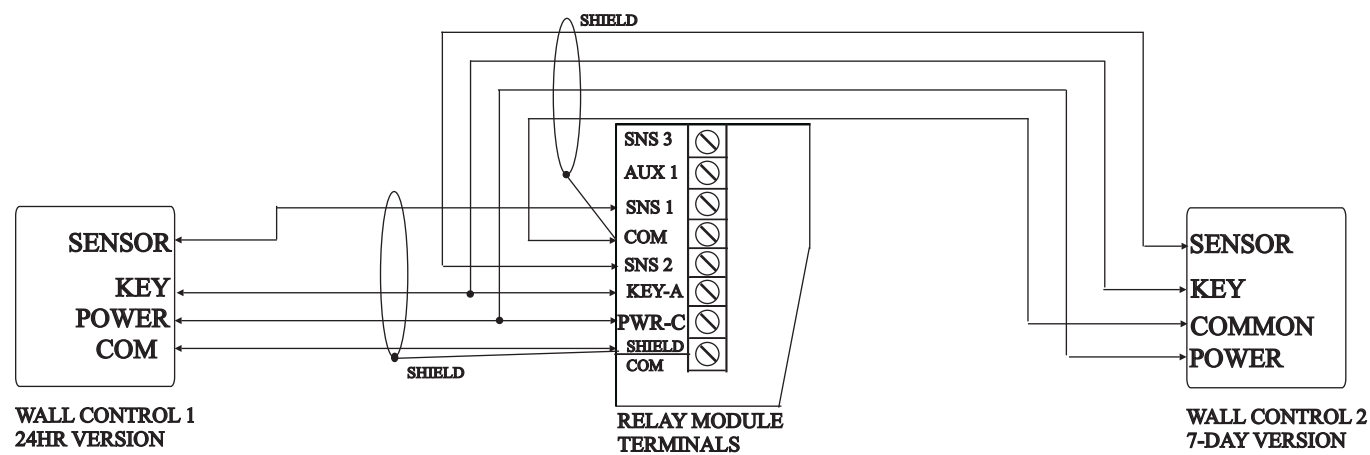

MENU 2. Press ON/OFF button to turn off Wall Control.

Press and hold **FAN CONTROL** button in, then press **TIMER Up** arrow and release **BOTH** buttons together.

Stage 1 “cool off”. **Zone 1** and **COOL** lights on. **OFF** light is flashing.
Press the **SET TEMP** Up or Down arrow to select new set point. Press **TIMER** button to accept new Off point.
Stage 1 “cool on”. **Zone 1** and **COOL** light on. **ON** light is flashing.
Press the **SET TEMP** Up or Down arrow to select new set point. Press **TIMER** button to accept new On point.
Repeat as above for other settings. **See Table below for adjustments.**
Note: press **FAN CONTROL** button anytime to exit Menu.
Only relevant stages will show depending on Air Conditioning Operation Mode selected.

Switching temperature differentials are referenced to Controller set point.

Heating and Cooling	Factory Settings	Temperature Adjustment	Lights displayed on Wall Control			
			ON	ON	ON	FLASHING
Stage1 Cool Off	0.5oC	0 to 9.0oC	COOL	ZONE 1		OFF
Stage1 Cool On	1.0oC	0.5 to 9.9oC	COOL	ZONE 1		ON
Stage2 Cool Off	1.0oC	0 to 9.0oC	COOL		ZONE 2	OFF
Stage2 Cool On	1.5oC	0.5 to 9.9oC	COOL		ZONE 2	ON
Stage3 Cool Off	1.5oC	0 to 9.0oC	COOL	ZONE 1	ZONE 2	OFF
Stage3 Cool On	2.0oC	0.5 to 9.9oC	COOL	ZONE 1	ZONE 2	ON
Stage1 Heat Off	-0.5oC	-0 to 9.0oC	HEAT	ZONE 1		OFF
Stage1 Heat On	-1.0oC	-0.5 to 9.9oC	HEAT	ZONE 1		ON
Stage2 Heat Off	-1.0oC	-0 to 9.0oC	HEAT		ZONE 2	OFF
Stage2 Heat On	-1.5oC	-0.5 to 9.9oC	HEAT		ZONE 2	ON
Stage3 Heat Off	-1.5oC	-0 to 9.0oC	HEAT	ZONE 1	ZONE 2	OFF
Stage3 Heat On	-2.0oC	-0.5 to 9.9oC	HEAT	ZONE 1	ZONE 2	ON

Menu 3. Overview Sections 1, 2 and 3. Press ON/OFF button to turn off Wall Control.

Press and hold **FAN CONTROL** button in, then press **TIMER Down** arrow. Release **BOTH** buttons together.

You will enter **Section 1** if using **LEASAM** Zone models **BM2-4Z**.
You will enter **Section 2** if using **LEASAM** non Zone models **BM2-GP**.
Note 1: Press **FAN CONTROL** button anytime to exit Menu.
Note 2: To move from **SECTION 1** to **SECTION 2** to **SECTION 3**. Press and release **TIMER** button.

Section 1. ZONES SETUP See page 4

Allows you to add or remove zones. Note: Minimum two zones

Allows you to assign (program) zone 2, 3, or 4 to sense temperature from a 2nd optional Sensor or Wall Control.

Section 2. FAN SETUP See page 4

To change factory fan speed selections available from Wall Control Pad.

To change factory fan operating mode Auto or Continuous selectable from Wall Control Pad to Continuous operation only.

Section 3. PARAMETERS SETUP See page 4.

Change functions or parameters for the following. See Section 3 table for factory settings and adjustments

- F1) Fan Run-On time. Time indoor fan will run-on when system is switched off in electric heating cycle.
- F2) Temperature operating mode. Change factory setting to non selectable automatic temperature changeover.
- F3) Sensor 1 Calibration. Allows you to offset sensor 1 temperature.
- F4) Sensor 2 Calibration. Allows you to offset sensor 2 temperature.
- F5) Compressor minimum off time delay (Anti-cycle).
- F6) Dirty Filter warning light. Allows you to extend or reduce time for filter warning light.
- F7) Reversing valve operating mode. To change reversing valve to operate in cooling.
- F8) Operating set up for optional Sensor 3. **See Sensor 3 Operating set up. Page 4**
- F9) Compressor Run Time - minimum time compressor must run for.

MENU 3.

Section 1. ZONES SETUP BM2-4Z only.

Enter Menu 3 as shown on previous page. i.e. Hold FAN CONTROL Press TIMER DOWN arrow, Release both.

2-1 will be displayed on screen. To assign Zone 2 to Sensor 2 Press SET TEMP UP arrow and see 2-2 displayed. To exit menu, Press FAN CONTROL button, or Press TIMER button to advance to Section 2, or

Press ZONE 3 button. 3-1 is displayed on screen. To use Sensor 2 Press SET TEMP UP arrow and see 3-2 displayed. To exit menu, Press FAN CONTROL button, or Press TIMER button to advance to Section 2, or

Press ZONE 4 button. 4-1 is displayed on screen. To use Sensor 2 Press SET TEMP UP arrow and see 4-2 displayed. To exit menu, Press FAN CONTROL button, or Press TIMER button to advance to Section 2.

NOTE: Always exit with the number of Zones you require i.e. exit with 3-1 displayed if you only have 3 ZONES Zone 1 is always assigned to sensor 1, normally 1 ZONE must remain on or see Page 2. Allow All Zones Turned Off.

Section 2. FAN SETUP Fan speeds and operating modes.

Enter Menu 3 as shown above. Press TIMER button to move to Section 2. Fan displayed Press SET TEMP Up arrow until lights displayed on Wall Control match required Fan settings. See Table below

Lights Displayed on Wall Control				Fan Speeds	Fan Operating Mode
CONT	HIGH			1	Fan runs continuous when the System is on. Cannot select Auto from Wall Control.
CONT	HIGH		LOW	2	
CONT	HIGH	MID	LOW	3	
	HIGH			1	Select Continuous or Auto from Wall Control. Auto will cycle the fan on and off with the temperature demand
	HIGH		LOW	2	
	HIGH	MID	LOW	3	

Factory Default Setting

Press FAN CONTROL button to exit menu, Press TIMER button to advance to Section 3.

Section 3. PARAMETERS SETUP See Table below for functions and parameters.

Press SET TEMP Up or Down arrow to select function or to adjust parameter. Press FAN CONTROL button to exit menu, Press TIMER button to advance to next Function.

Functions	Factory Default	Range	Adjustments	Lights displayed on Wall Control Pad				Comments	
				7-Segment Display	ON	ON	ON		FLASHING
F1. Fan Run-On	0.0Mins	0.5-5Mins	0.5Mins	0,0	HIGH	LOW	MID	RUN ON	Must set a value to enable Boost heat
F2. Temperature operating mode	Cool/Auto/Heat		Auto		COOL	AUTO	HEAT		Select Auto or Heat or Cool from Wall Pad Automatic changeover only
F3. Sensor 1	0.0	-2.5 to 2.5	0.1oC	0,0	ROOM	ZONE 1			Offset temperature sensor 1
F4. Sensor 2	0.0	-2.5 to 2.5	0.1oC	0,0	ROOM	ZONE 2			Offset temperature sensor 2
F5. Comp Delay	0.0	0-8.5Mins	0.5Mins	0,0	COOL	AUTO	HEAT		Compressor Anti-Cycle Delay
F6. Dirty Filter	160 Hours	100 to 600	10 Hours	160	FILTER				Filter timer measures fan running time
F7. 4 Way valve	rH		rC	r H					Energise reversing valve in Cooling if needed.
F8. Pre-heat	PH		AC	PH					Pre-Heat or Add on Cool if sensor 3 is detected
F9. Comp Run	0.0	0-8.5Mins	0.5Mins	0,0	COOL	AUTO	HEAT	ON	Minimum Compressor run time

Sensor 3 Operating set up.

Optional Sensor 3 is automatically detected when connected to SNS 3 / COM terminals on the Relay Module. **Preheat.** Fix Sensor securely to coil of indoor Fan. **Note:** if no sensor 3 connected, preheat delay of 16secs. is imposed. **Add on Cool.** Sensor 3 senses Ambient temperature. See Tables below for system operation in “Preheat” or “Add on Cool” mode.

FAN and COMPRESSOR Temperature Control Table in Preheat option

Heat pump	Heat LED	Evaporator Coil Temp.	Fan Speed	Compressor	Description of operation
	Blinking	< 15.0 degC	Off	On	Indoor fan off
	On	> 30.0 degC	Low	On	Indoor fan on low speed
	On	> 32.0 degC	Selected	On	System in Normal Operation
	On	> 68.0 degC	Selected	Off	Compressor off to prevent high pressure trip.
		< 50.0 degC	Selected	On	Normal Operation

FAN and COMPRESSOR Temperature Control Table in Add On Cool option

Heat pump with Auxiliary Heat	Heat LED	Evaporator Coil Temp.	Fan Speed	Compressor	Description of operation
	On	< 4.0 degC	Selected	Off	*Auxiliary heat replaces Heat Pump Operation
	On	> 5.0 degC	Selected	On	Normal Operation

Power Wiring Diagrams

Typical connections for LEASAM models BM2-4Z. Notes. Check A/C Unit wiring diagram. Damper actuator outputs are 240vac or 24vac.

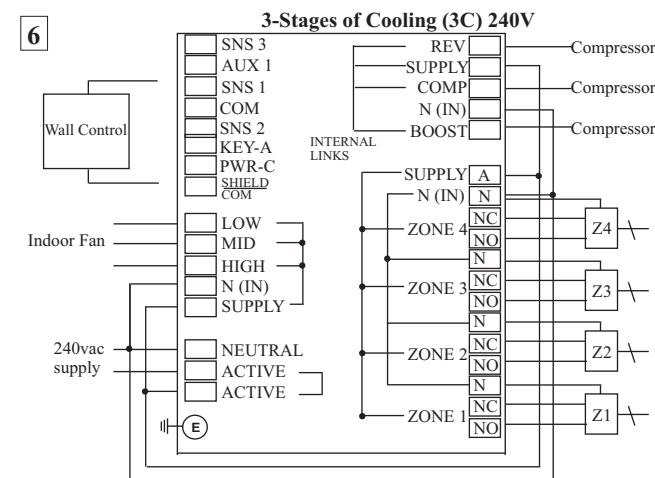
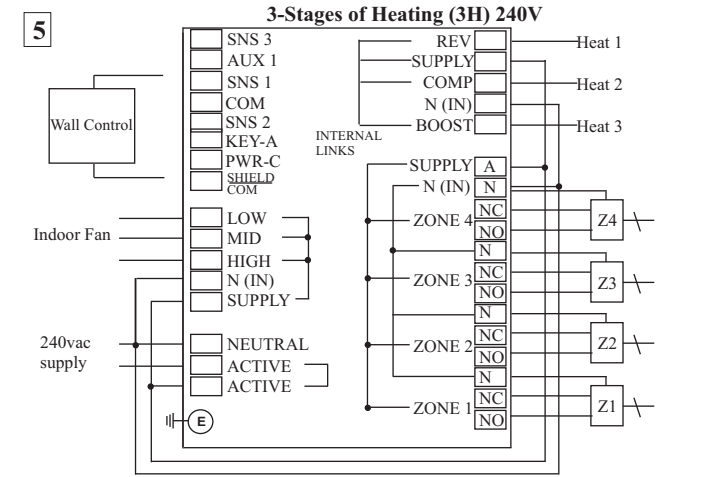
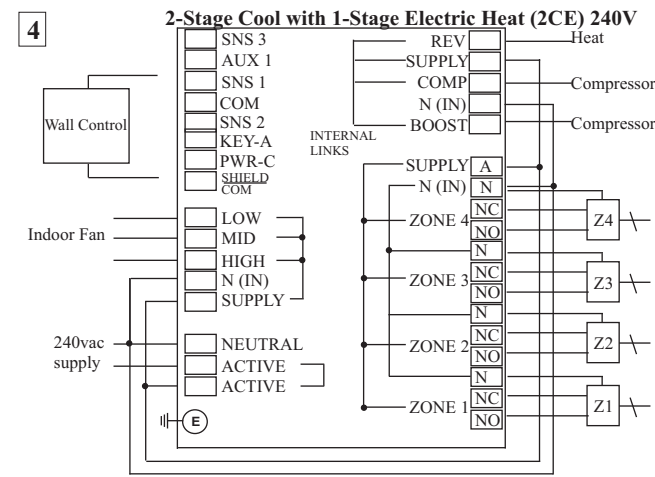
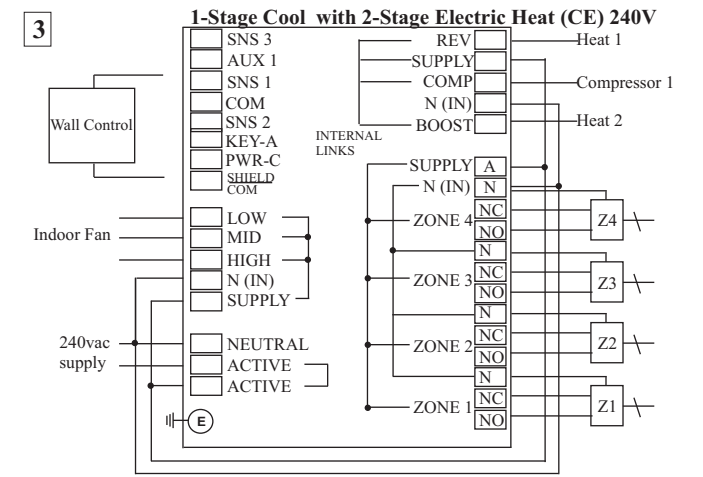
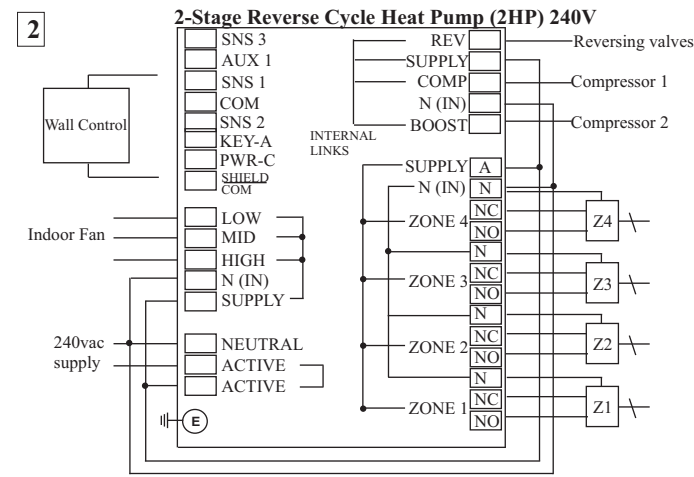
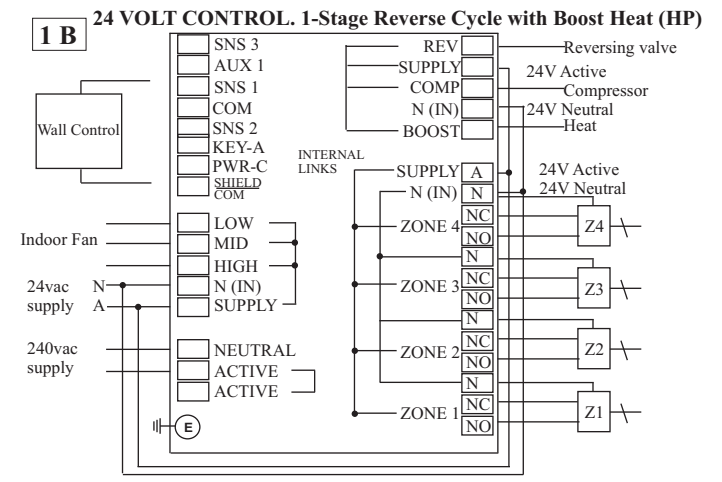
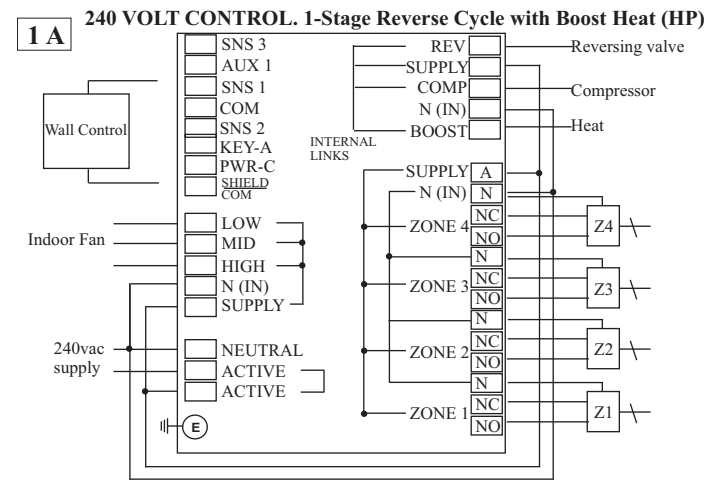

SPECIFICATIONS	
Power supply	240 Volts 50Hz
Relays. Three(Fan)	20 Amps Res @ 250 volts
Relays. Max seven (zone model)	5Amps Res @ 250 volts
Set point range - adjustable	16oC to 28oC
Dead band from heating off to cooling on - adjustable	1.5K
Switching differential - adjustable	0.5K
Fan run on (Electric heating only) - adjustable	30 Seconds
Compressor start delay - adjustable	0 Seconds
Sensor. Integral on wall control (remote sensor option)	10k @ 25oC
Maximum Wall Controls allowed per system	2
Maximum sensors allowed per system	2
Recommended cable size	14/020 shielded